



DS-1697ZJ

Anticorrosive Wall Mounting Bracket

Features:

- Stainless steel 316L material
- Anti-corrosion design for adverse environment
- Design of safety rope for more convenient installation

Dimension:

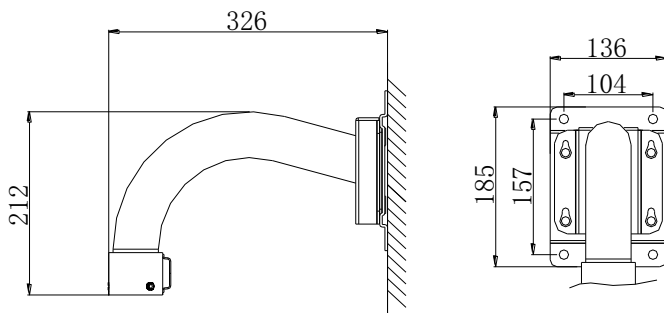

Order Model:

DS-1697ZJ

Parameter:

| | |
|----------------------|-------------------------------------|
| Model | DS-1697ZJ |
| Parameter | Anticorrosive wall Mounting Bracket |
| Range of Application | For speed dome wall mounting |
| Material | Stainless steel 316L |
| Dimension | 104×212×326mm |
| Weight | 2300g |

Notice:

- The bracket should be installed on flat wall
- Load capacity of pole should be more than 3 times the weight of camera and bracket
- Load capacity of clamp is 15KG

Installation steps:

- ① Choose the appropriate wall and paste the template of pre-installed plate

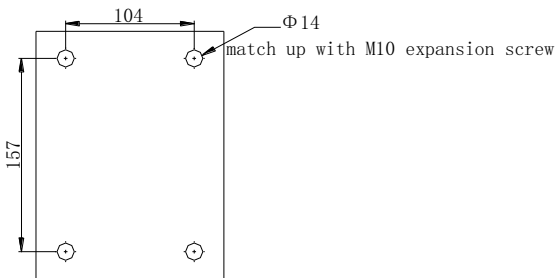

- ② Drill the Screw holes and twist the expansion bolts

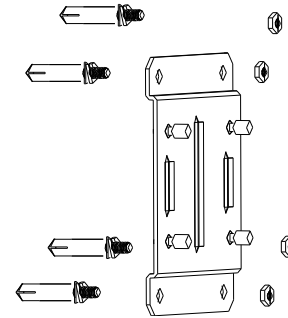

- ③ Fix the pre-installed plate

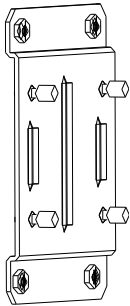

- ④ Install the bracket to the pre-installed plate

